

MANDATORY SERVICE BULLETIN

DATE: April 18, 2008

Service Bulletin No. 366B
(Supersedes Service Bulletin No. 366A)
Engineering Aspects are
FAA Approved

SUBJECT: Carburetor Throttle Body Screw Inspection

MODELS AFFECTED: All Lycoming engines equipped with Marvel-Schebler, Facet, Precision, or Volare updraft carburetor models MA-3A, MA-3PA, MA-3SPA, MA-4SPA, MA-4-5, MA-4-5AA, and MA-6AA.

TIME OF COMPLIANCE: Within the next 50 hours of engines operation and at each 100 hours of engine operation thereafter, or anytime fuel stains are evident.

Instances have been reported of leakage through the gasket between the bowl assembly and throttle body of the carburetor, evidenced by fuel stains in the area of the leak. Leakage of this type may be accompanied by loose screws that attach the bowl and throttle body.

See Figure 1 for illustrative example of the throttle body attaching screws.

INSTRUCTIONS FOR COMPLIANCE:

1. Check the carburetor for evidence of fuel stains on the outside of the bowl along the parting line.
2. Check for movement between the throttle body and bowl.
3. Check each throttle body to bowl attaching screw for looseness by attempting to move the screw and/or locktab washers with your fingers.



Do not attempt to turn the screw with a screwdriver. Turning the screw with a screwdriver may compromise the lock washers and increase the likelihood that the screws will become loose.

4. If there is evidence of fuel stains, movement between the throttle body and bowl, or the throttle body to bowl attaching screws are loose then remove the carburetor in accordance with the applicable engine and airframe service manuals. Send the carburetor to a qualified repair station for troubleshooting and repair. For the most recent listing of qualified repair stations contact Volare Carburetors at the following:



ISSUED			REVISED			PAGE NO.	REVISION
MO	DAY	YEAR	MO	DAY	YEAR		
09	14	73	04	11	08	1 of 2	B

Volare Carburetors LLC
P.O. Box 44
211 Chase Street
Gibsonville, NC 27249
Phone: (336) 449-5054

5. Reinstall the carburetor in accordance with the applicable engine and airframe service manuals.
6. Inspect the engine installation for damaged or worn motor mounts, and/or evidence of out of balance conditions. Take appropriate action to correct discrepant conditions found during the inspection.
7. Make an appropriate logbook entry showing compliance with this Service Bulletin.

If after compliance with this Service Bulletin there is continued fuel leakage, or if there are other conditions not specifically described in this Service Bulletin then contact Lycoming Product Support at 570-323-6181.

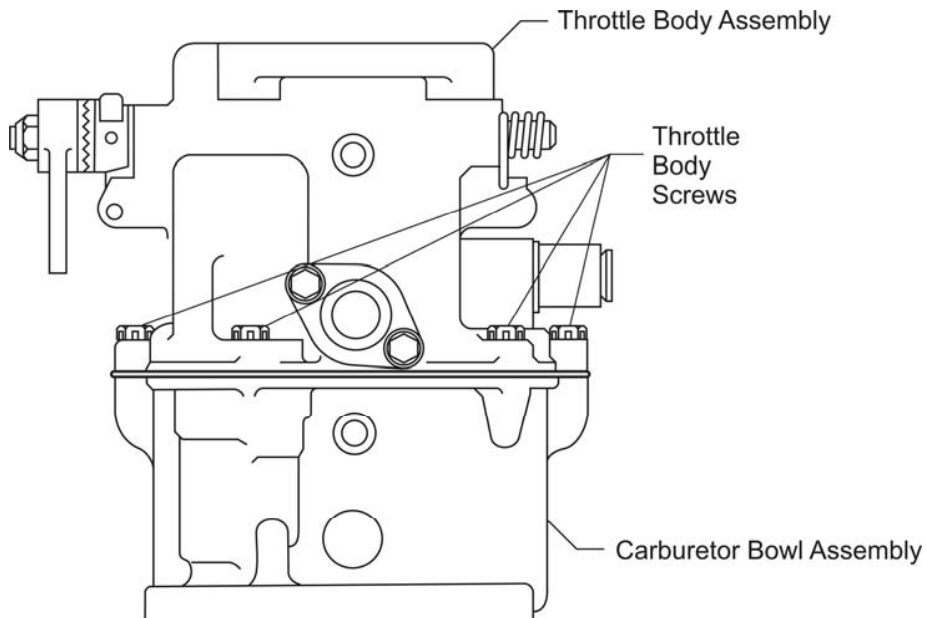

Models MA-3A, MA-3PA, MA-3SPA, and MA-4SPA have four screws. Models MA-4-5, MA-4-5AA, and MA-6AA have six screws.

Figure 1. Illustrative Example of Throttle Body Attaching Screws

ISSUED			REVISED			PAGE NO.	REVISION	S.B. 366
MO	DAY	YEAR	MO	DAY	YEAR			
09	14	73	04	11	08	2 of 2	B	